

Sub-Vendor:	Vendor:			Contractor:	Owner/Purchaser:
		Packing and shipping procedure			
	Arya Mabna Payesh company	Vendors Doc. No.:	Rev. :00		

Index

Page

Contents

SCOPE	3
PURPOSE	3
PACKING.....	3
General.....	3
PACKAGE DIMENSION ANDWEIGHT	4
SELECTION OF PACKAGES STYLE.....	4
Wood Case or Crate	4
Wood skid.....	5
Bundle	5
Pallet.....	5
MARKINGSPECIFICATION	5
INSPECTION	5
TRANSPORTATION AND LOADING METHOD	6
Direct contact to ground shall not be permitted.	6
Every package shall be placed on pallet or sleeper.....	6
LOADING METHOD ON MOTHER SHIP AND OTHERS	6
HAZARDOUS GOODS	6
RESPONSIBILITIES ANDWARRANTIES.....	7



Sub-Vendor:	Vendor:			Contractor:	Owner/Purchaser:
		Packing and shipping procedure			
	Arya Mabna Payesh company	Vendors Doc. No.:	Rev. :00		

ANNEX 1. PACKING STYLE	8
ANNEX 2. APPLICATION STANDARDS OF PACKING STYLE	10
ANNEX 3. POINT OF MAIN AND AUXILIARY SHIPPING MARK	11
ANNEX 4. MAIN SHIPPING MARK	12



Digitally signed by AMP
 DN: C=IR, OU=AMP, O=AMP,
 CN=AMP,
 E=info@ampva9eco.com
 Reason: I am approving this
 document with my legally binding
 signature
 Location: your signing location
 here
 Date: 2021.12.18 16:56:
 13+03'30"
 Foxit PDF Editor Version: 11.0.1

Sub-Vendor:	Vendor:			Contractor:	Owner/Purchaser:
		Packing and shipping procedure			
	Arya Mabna Payesh company	Vendors Doc. No.:		Rev. :00	

SCOPE

This procedure is intended to specify the requirements of packing and marking and handling of the valves Projects

PURPOSE

This procedure contains the requirements for packaging and transportation to protect the packages against an impact and vibration during transportation and variety climate condition.

And also describes the packaging procedures to protect the packages against corrosion, contamination and physical damage during handling and long-term storage.

PACKING

General

Equipment and materials must be export packed as per European Industrial Packaging Specification such as SEI 1992 EDITION. Categories of packing are defined in the last 1992 Edition of SEI.

Before packaging the items, the inspection for paint shall be performed.

Product should be pack after elimination of oil & rust before packing.

Machined and unprotected metal surface susceptible to salt water or atmospheric corrosion will be coated with a suitable temporary preventive to protect items from corrosion in transit and outside storage at site.

Lifting points will be clearly marked on the package and slinging shall be performed on a specified location.

The items shall be adequately blocked and strapped to prevent damage during transit, handling and storage.

Small loose items or spare parts shall be packed separately.

Butt welded ends shall be protected with a plywood or plastic cap using an approved adhesive tape.

Flanged ends will be protected by plywood or plastic cover or steel cover with four bolts (Tie cable) at least.

Sub-Vendor:	Vendor:			Contractor:	Owner/Purchaser:
		Packing and shipping procedure			
	Arya Mabna Payesh company	Vendors Doc. No.:	Rev. :00		

pine wood shall be used for packaging unless otherwise specified in the contract.

Skid wood or wood bracing cannot come in direct contact with the commodity. Contact surface between equipment and wooden skid will be protected by placing cushioning material (toilon or rubber pad)

Stainless steel material and carbon steel material shall be packed separately.

If the order stipulate the high alloy steel (stainless steel etc.) shall is to be treated with acid cleaning, the equipment must be protected by vinyl wrapping after cleaning.

Spare parts have to be packed using the water proof wooden case and sent separately from the respective main shipment. Prior to packing, be sure to carry out customer's witness inspection.

Consumables have to be packed separately. In particular, they must not be packed together with any kind of device or tools for temporary use.

Polymer sheeting used to protect insulation from moisture damage shall not include chlorides

or other chemicals that can release toxic or objectionable odors upon heating to operating conditions.

Tools shall be packed in an individual, rugged wooden box and marked as "special tools".

silica gel packets shall use to absorb internal valves moisture and keep them dry.

PACKAGE DIMENSION ANDWEIGHT

Package size and weight shall be decided after considering the delivery condition and handling method.

SELECTION OF PACKAGES STYLE

Depend on the property, weight and shape of item, package type shall be selected as wood case, crate, skid, bundle or pallet etc.

Wood Case or Crate

This type of packaging shall be applied for the item requiring waterproof or small pieces readily being missed. Needs special care for stacking during handling and damage by contact between components transportation to prevent

Sub-Vendor:	Vendor:			Contractor:	Owner/Purchaser:
		Packing and shipping procedure			
	Arya Mabna Payesh company	Vendors Doc. No.:	Rev. :00		

Framed case shall be applied for the item, such as instrumentation or electric equipment, requiring complete protection from water or moisture. Tarpaulin or watertight sheet will be used inside case

For the items requiring partial waterproof, a crate or open type crate shall be used.

All boxes should be designed in consideration of the weight when loading them. (The standards of KS(Korea Standard) and JIS(Japanese Industrial Standard) is applied to the Manufacture of boxes used for exports.)

Wood skid

This type of packaging shall be applied for the items which are weatherproof and strong enough to external impact, such as steel column, vessel and harp assembly etc.. wooden skid and goods will be tightened with steel wire or Cord strap, stud bolts as Appendix 3.

Bundle

This type of packaging shall be applied for the items, which are weatherproof and simple shape. The quality of goods should not be affected by weather during transportation and storage as bundle. The bundle should be properly packed to protect goods from external impact during handling, transportation and storage.

Bare Materials This type shall be applied for the items, which are waterproof and strong enough to external impact. This type of goods could be handled without packaging and also should be proper for transportation, storage.

Pallet

This type of packaging shall be applied for the items, which are not enough to protect goods with skid or bundle. The skid or bundle for shell plates or thin plates could cause deformation on goods during transportation and storage. Needs special care for stacking this type to protect goods from damage.

MARKINGSPECIFICATION

Main shipping Markings for each package shall be in accordance pattern in ANNEX 4.

INSPECTION

The packing process / procedure shall be inspection by the BUYER, or the CLIENT, or such duly authorized agent appointed by the BUYER or the CLIENT during all stages of packing work.

Sub-Vendor:	Vendor:			Contractor:	Owner/Purchaser:
		Packing and shipping procedure			
	Arya Mabna Payesh company	Vendors Doc. No.:	Rev. :00		

TRANSPORTATION AND LOADING METHOD

Direct contact to ground shall not be permitted.

Every package shall be placed on pallet or sleeper.

Wood case, especially electric instrumentation, shall be protected from the weat during transportation and stocked indoors.

Enough numbers of sleepers shall be used to prevent excessive deformation due to rock and roll during transportation.

The deformation during storage shall be also considered and enough sleepers shall be place under the item.

Package shall be fastened securely with chain or wire to prevent damage during handling and transportation. Especially engineered lug and lacing shall be used for steel frame.

The requirements described above shall be applied as same as on part and site.

The deformation during storage shall be also considered and enough sleepers shall be place under the item.

Package shall be fastened securely with chain or wire to prevent damage during handling and transportation. Especially engineered lug and lacing shall be used for steel frame.

The requirements described above shall be applied as same as on part and site.

LOADING METHOD ON MOTHER SHIP AND OTHERS

If wire is used for handling goods, the protection cover shall be used on the contact point to project goods.

The sleepers shall be used on the ship as well as during storage to prevent direct contact between goods and ground.

HAZARDOUS GOODS

The packaging for inflammables such paint or thinner material should follow the IMO code. The certificate according to the regulation should be submitted before shipment.

Sub-Vendor:	Vendor:  Arya Mabna Payesh company	Packing and shipping procedure Vendors Doc. No.: Rev. :00	Contractor:	Owner/Purchaser:
-------------	--	---	-------------	------------------

RESPONSIBILITIES AND WARRANTIES

Supplier shall be responsible for compliance with these instructions and the choice of category for packing, according to the nature of the supplies and transport facilities used.

Contractor reserves the right to inspect the packing at any time, and to reject it when it does not meet packing requirements.



Sub-Vendor:	Vendor:			Contractor:	Owner/Purchaser:
		Packing and shipping procedure			
	Arya Mabna Payesh company	Vendors Doc. No.:		Rev. :00	

Annex 1: PACKING STYLE

Case or Crate

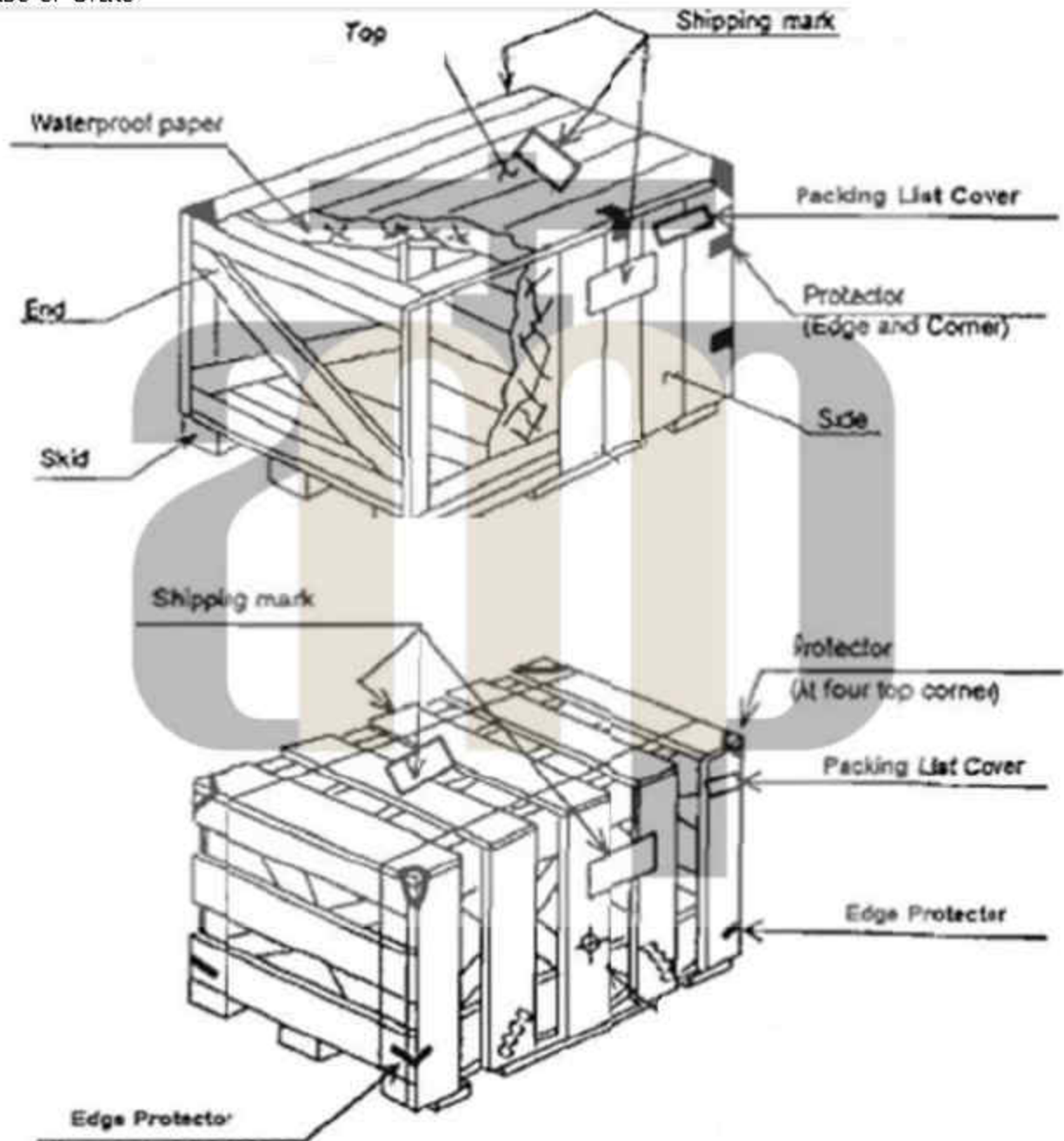

1.1 MAJOR FRAME CONSTRUCTION OF CASE OR CRATE

Sub-Vendor:	Vendor:  Arya Mabna Payesh company	Packing and shipping procedure	Contractor:	Owner/Purchaser:
			Vendors Doc. No.:	Rev. :00

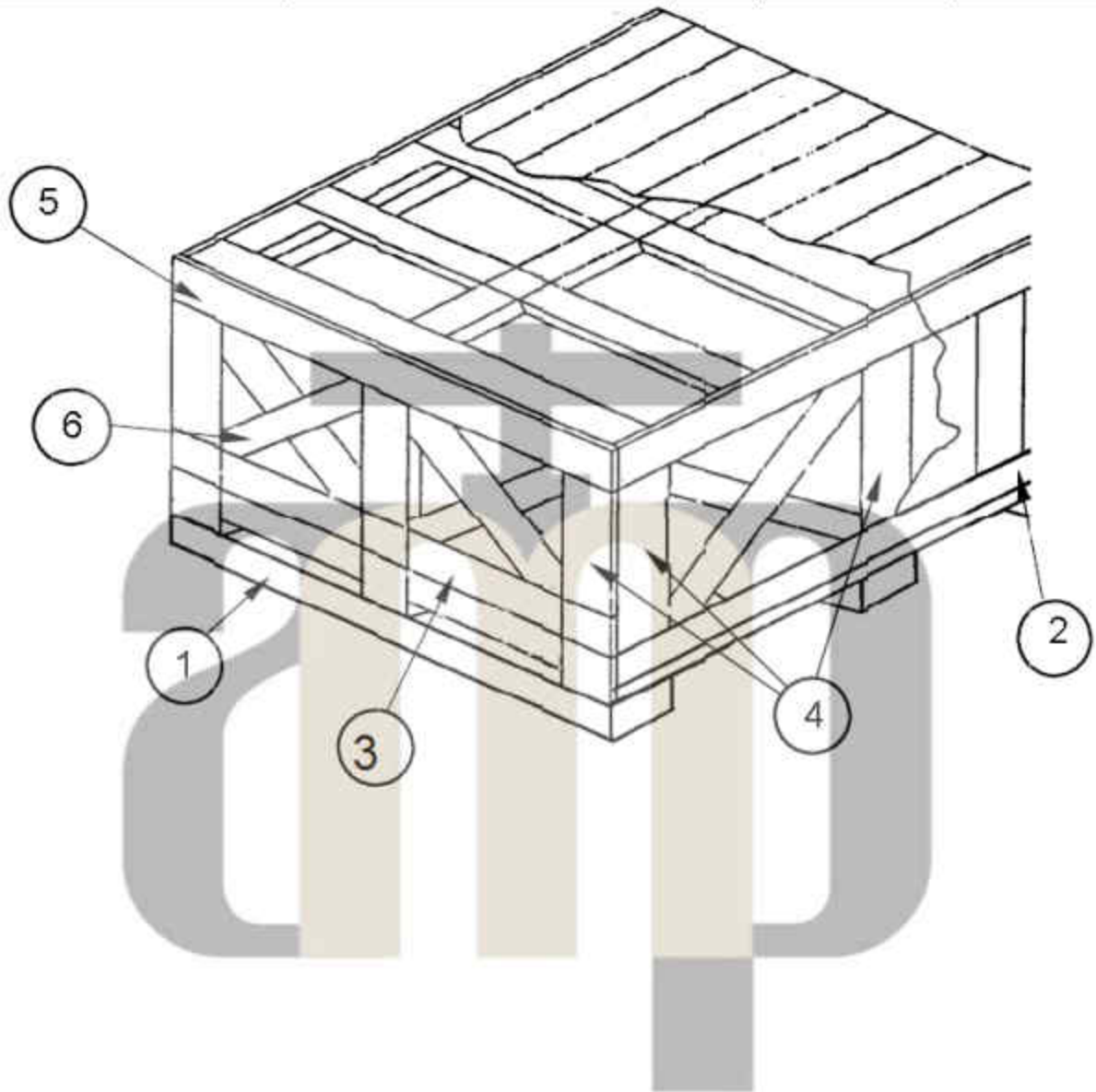

Sub-Vendor:	Vendor:			Contractor:	Owner/Purchaser:
		Packing and shipping procedure			
	Arya Mabna Payesh company	Vendors Doc. No.:		Rev. :00	

Annex 2: APPLICATION STANDARDS OF PACKING STYLE

PACKING STYLE	APPLICATION	ITEMS TO BE APPLIED
Water prof case		Valves & pipe, fitting (4 inch and below)
Crate		Valves & pipe, fitting (above 4 inch)

Sub-Vendor:	Vendor:	Packing and shipping procedure	Contractor:	Owner/Purchaser:
		Vendors Doc. No.:	Rev. :00	
	Arya Mabna Payesh company			

2. POINT OF MAIN AND AUXILIARY SHIPPING MARK

